



**May 21, 2019**  
**ADDENDUM NO. 2**

Project: DAWSONVILLE FARMERS MARKET BID PACKAGE

To all prospective Bidders:

The additions and/or deletions contained in this Addendum shall be made a part of the plans and specifications and contract documents for the above described project, and shall be subject to all applicable requirements there under, as if originally shown and/or specified.

1. There has been no geotechnical borings for soil composition or structural stability prepared for this site.
2. Under slab termite treatment shall be applied below the restroom building only.
3. Timber posts shall be treated with a clear sealer. Timber trusses exposed elements shall be treated with a clear sealer. If wood soffit materials are provided, then the wood materials shall be painted with a paint sealer. Refer to specifications Section 099000 Painting and Coating.
4. Sheet A2 references options regarding the fascia and soffit materials. A wood soffit system would be preferred and a metal soffit and fascia system would be considered an alternate. Wood soffit system shall be included with lump sum bid and an alternate price for the metal soffit system shall be provided.
5. The project is not exempt from sales tax.
6. The roofing material warranty length shall be fifteen years.
7. The roof panel finish shall receive a two coat fluoropolymer finish. An alternate price for a two coat fluoropolymer metallic shall be provided.
8. There are no gutters and down spouts required at this time for the Farmers Market Pavilion.
9. The split face stacked jointed block shall be integral color to be determined by the owner. Contractor shall submit color selections or samples for the Owner's review and approval.
10. In reference to A/S-4, each post has (4) 7" lag screws and (4) 10" lag screws as shown.
11. Column footings under the slab turndown (reference A/S-4) are not required at each post.
12. Glulam beams are the required eave framing for the Farmers Market Pavilion; refer to Section D/S-4.



13. Labels for sections B/S-4 and C/S-4 have been swapped as shown below:

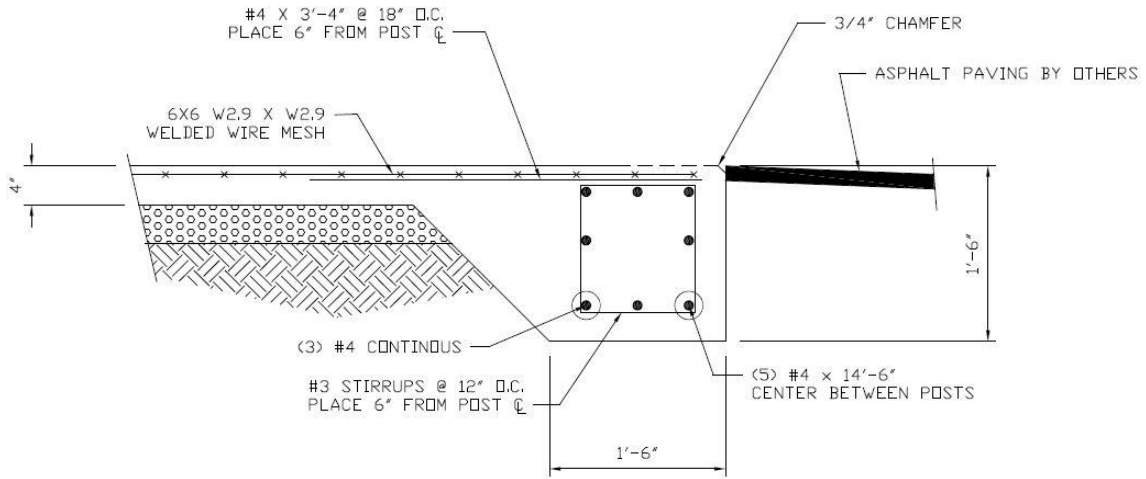

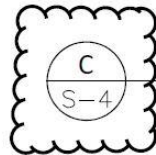
 SECTION  
SCALE 1" = 1'-0"

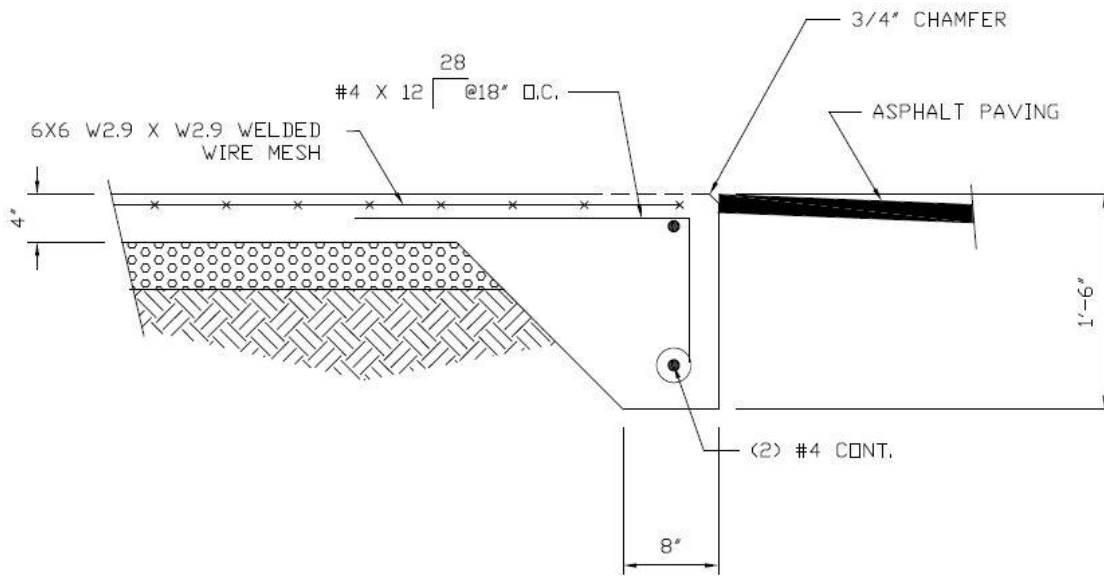

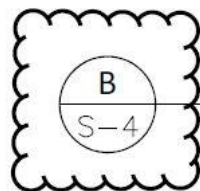
 SECTION  
SCALE 1" = 1'-0"



14. There are no architectural drawings associated with the pavilion. Farmers market pavilion finishes are below:
  - a) Roofing: Shall be metal roofing, panels to match the restroom building per specification Division 076100 and Division 076200, respectively.
  - b) Posts: Shall have a clear seal finish.
  - c) Gable Siding: Shall be HardiPlank fiber cement siding per specification Division 074646.
  - d) Soffits: Wood soffits and fascia shall be painted finish with a protective sealer. Metal soffit and fascia will be considered as an alternate.
  - e) Timber Trusses: Exposed elements of the timber trusses shall be stained.
15. Prevailing wages per the Davis-Bacon Act are not required for this project as it is not grant funded.
16. Liquidated damages are not included with this project.
17. Underground conduit for future voice/data is not proposed at this time.
18. Under slab drainage will not be required for this project.
19. Modifications to the timber frame trusses shown in the construction drawings are not allowed.
20. White Pine is not acceptable in lieu of southern yellow pine for the Farmers Market Pavilion.
21. The City of Dawsonville will provide and install a stop sign at the parking lot exit.
22. The restroom building shall have the following finishes:
  - a) Wood columns shall be stained.
  - b) The wood soffit and fascia system shall be painted with a protective sealer. Provide alternate costs for a metal soffit and fascia system.

\*\*\*RECEIPT OF THIS ADDENDUM IS TO BE ACKNOWLEDGED ON THE BID FORM\*\*\*

**END OF ADDENDUM NO.2**